

AIR FORCE T.O. 35C2-3-442-14  
ARMY TM5-6115-600-24P  
NAVY NAVFAC P-8-628-24P  
MARINE CORPS SL-4-07464B

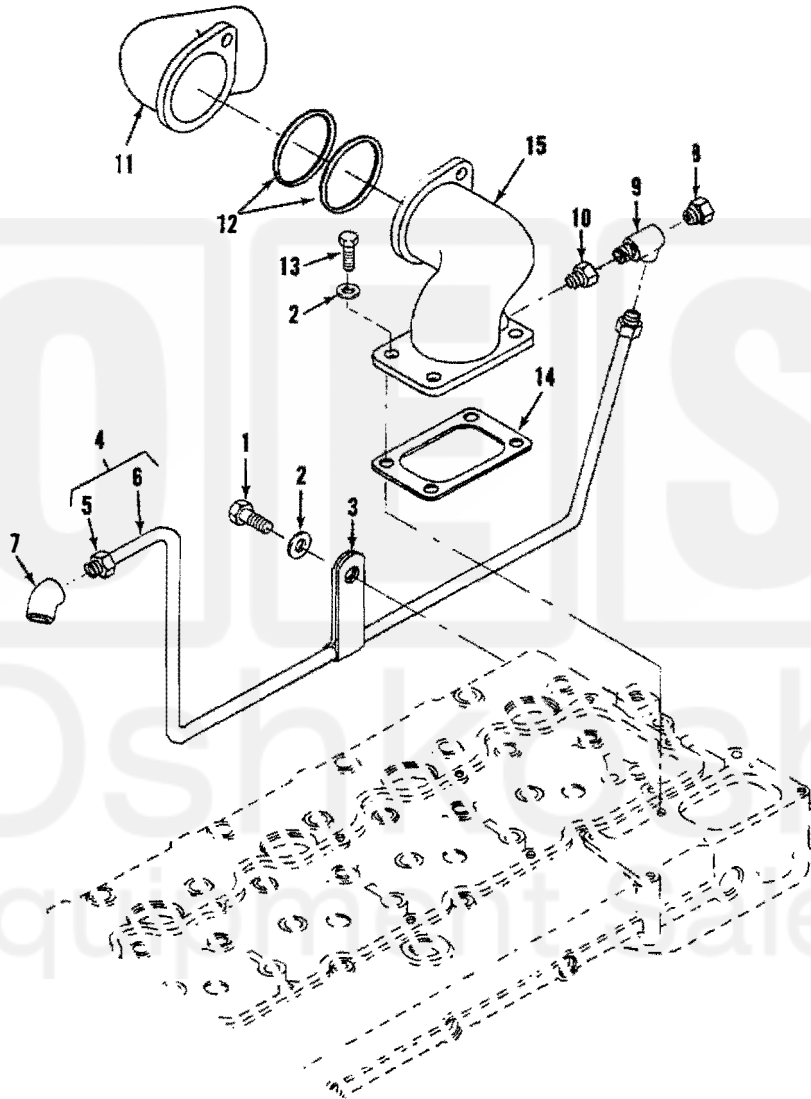

Figure 54. Air Lines

SECTION II. REPAIR PARTS FOR ORGANIZATIONAL, INTERMEDIATE (FIELD),  
 (DIRECT AND GENERAL SUPPORT) AND DEPOT MAINTENANCE

(1) ILLUSTRATION		(2) SMR CODE				(3) USMC		(4)	(5) DESCRIPTION USABLE ON		(6)	(7) QTY INC IN UNIT	(8) USMC QTY PER EQUIP
a	b	a	b	c	d	a	b	NATIONAL STOCK NUMBER	REF NUMBER & MFR CODE	CODE	U/M		
FIG NO.	ITEM NO.	ARMY	AIR FORCE	NAVY	USMC	SSI	REPL FACTOR						
									GROUP 10 - ENGINE				
									TURBO CHARGER				
55													
55	1	PAFZZ	PAFZZ	PAHZZ	PAHZZ	D	.008	5305-00-269-3216	BOLT S1590	11083	EA	2	6
55	2	PAFZZ	PAFZZ	PAHZZ	PAHZZ	D	.008	6310-00-243-6947	NUT 8M2296	11083	EA	6	10
55	3	PAOZZ	PAFZZ	PAHZZ	PAHZZ	D	.013	2815-00-994-7407	RING SL8854	11083	EA	1	1
55	4	PAFZZ	PAFZZ	PAHZZ	PAHZZ	D	.006	2990-00-981-1041	SUPPORT, ENGINE ELBOW SL7632	11083	EA	1	1
55	5	PAOZZ	PAFZZ	PAHZZ	PAHZZ	D	.013	2910-00-994-7409	RING SL8855	11083	EA	1	1
55	6	PAFZZ	PAFZZ	PAHZZ	PAHZZ	D	.006	2990-00-177-3449	COUPLING 6L8968	11083	EA	1	1
55	7	PAFZZ	PAFZZ	PAHZZ	PAHZZ		.030	5330-00-074-3773	PACKING, PREFORMED, P/O KIT P/N 5P9117 4L8337	11083	EA	4	8
55	8	PAFZZ	PAFZZ	PAHZZ	PAHZZ	D	.006	2990-01-032-7257	PIPE 6L3052	11083	EA	1	2
55	9	PAOZZ	PAFZZ	PAHZZ	PAHZZ	D	.008	5305-00-269-3215	BOLT MS90725-65	96906	EA	2	2
55	10	PAOZZ	PAFZZ	PAHZZ	PAHZZ	D	.010	5310-00-514-6249	WASHER, LOCK 3B4506	11083	EA	4	47
55	11	PAOZZ	PAFZZ	PAHZZ	PAHZZ		.030	5330-00-931-8048	GASKET, P/O KIT P/N 5P9117 156395	11083	EA	1	1
55	12	PAOZZ	PAFZZ	PAHZZ	PAHZZ	D	.008	5306-00-263-7301	BOLT L1351	11083	EA	2	14
55	13	PAOZZ	PAFZZ	PAHZZ	PAHZZ		.030	5330-00-989-3295	GASKET, P/O KIT P/N 5P9117 154810	11083	EA	1	1
55	14	PAFZZ	PAFZZ	PAHZZ	PAHZZ	D	.008	5306-00-255-4877	BOLT 6L8550	11083	EA	2	2
55	15	PAFZZ	PAFZZ	PAHZZ	PAHZZ	D	.008	6310-00-243-6947	NUT 8M2296	11083	EA	4	10
55	16	PAFZZ	PAFZZ	PAHZZ	PAHZZ	D	.010	5310-00-209-4516	WASHER M5839	28298	EA	4	4
55	17	PAFFF	PAFFF	PAHHH	PAHHH		.008	2950-00-498-3765	TURBOCHARGER ASSY 407640-9 8S1918	70210 11083	EA	1	1
55	18	PAFZZ	PAFZZ	PAHZZ	PAHZZ	D	.008	5305-00-151-9899	SCREW 2F808	11083	EA	2	2
55	19	MDO	MDO	MOD	MDO			9905-01-053-4809	PLATE, IDENTIFICATION 4069-43 8S8097	70210 11083	EA	1	1
55	20	PAFZZ	PAFZZ	PAHZZ	PAHZZ	D	.008	2950-00-950-2470	CLAMP 3S5129	11083	EA	1	1
55	21	XB	XB	XB	XB				HOUSING ASSY 407009-73 8S5166	70210 11083	EA	1	1
55	22	PAFZZ	PAFZZ	PAHZZ	PAHZZ	D	.008	5305-00-191-8284	BOLT 3S5126	11083	EA	7	13
55	23	PAFZZ	PAFZZ	PAHZZ	PAHZZ	D	.008	2950-00-948-1611	PLATE, LOCKING 406064 3S5128	70210 11083	EA	3	3